

# REGOLE PER LA COMPILAZIONE DELL'ORDINE

## RULES FOR FILLING IN THE ORDER FORM

1- INDICARE PROPRIA INTESTAZIONE E RIFERIMENTO DELL'ORDINE  
1-

SCHEDE D'ORDINE



**GLASS-500**

Ciente - Customer \_\_\_\_\_

Rif. - Ref. \_\_\_\_\_

**CONFIGURAZIONE DEI SET E APERTURE - SETS CONFIGURATION AND OPENINGS**

 GLASS-500 SET 2 GLASS-500 SET 6	 GLASS-500 SET 3 GLASS-500 SET 7	 GLASS-500 SET 4 GLASS-500 SET 8	 GLASS-500 SET 5 GLASS-500 SET 9
<input type="checkbox"/> Set 2 2 ante/panels <input type="checkbox"/> Set 6 2+2 ante/panels	<input type="checkbox"/> Set 3 3 ante/panels <input type="checkbox"/> Set 7 3+3 ante/panels	<input type="checkbox"/> Set 4 4 ante/panels <input type="checkbox"/> Set 8 4+4 ante/panels	<input type="checkbox"/> Set 5 5 ante/panels <input type="checkbox"/> Set 9 5+5 ante/panels
 Vista interna/Internal view	 Vista interna/Internal view	 Vista interna/Internal view	 Vista interna/Internal view

2- SCEGLIERE LA CONFIGURAZIONE DEL SET  
2- CHOOSE THE SET CONFIGURATION

3- INDICARE SENSO DI APERTURA  
3- INDICATE OPENING DIRECTION

4- INDICARE SPESSORE VETRO  
4- INDICATE GLASS THICKNESS

5- LARGHEZZA ED ALTEZZA ESECUTIVA INFISSO  
5- INDICATE WIDTH AND HEIGHT



6- INDICARE COLORE STRUTTURA  
6-

**CARATTERISTICHE GENERALI - GENERAL FEATURES**

<b>Spessore vetro - Glass thickness</b> <input type="checkbox"/> 10 mm <input type="checkbox"/> 12 mm	<b>Misure - Measures</b>  H ESECUTIVA EXECUTIVE H L ESECUTIVA EXECUTIVE L	<input type="checkbox"/> <input checked="" type="checkbox"/> <input type="checkbox"/> <input checked="" type="checkbox"/> <input type="checkbox"/> <input checked="" type="checkbox"/> H SERRATURA H LOCK			
<b>Colore struttura - Colour structure</b> ALLUMINIO ANODIZZATO AN	ANTRACITE C2	BIANCO OPACO RAL 9010 C5	AVORIO OPACO RAL 1013 C7	MARRONE RAL 8019 BW	RAL .....

**OPTIONALS**

LG-521*  Catenacciolo per apertura centrale Locking bolt for central opening	LG-510 	LG-511 	LG-512 
LG-516-B Contropiastra per serratura Strike palte for lock	PRO-V784 	PRO-V769-2FLG Controserratura Strike box	PRO-V784 PO-TC 
PRO-V532 AN #50 	PRO-V524 AN #60 	LG-503 Guida incassata 3 vie anodizzata Anodized recessed floor profile 3-ways	LG-507 Guida incassata 4 vie anodizzata Anodized recessed floor profile 4-ways
		LG-515 Guida incassata 5 vie anodizzata Anodized recessed floor profile 5-ways	

SCHEDE D'ORDINE

186

9- PER GLI OPTIONAL INDICARE TIPOLOGIA E QUANTITÀ  
9-

7- INDICARE SE IN POSSESSO DI UN MULETTO  
7-

8- SE SI ORDINA LA SERRATURA INDICARE L'ALTEZZA  
8-

## CONSIGLI PER IL CORRETTO RILIEVO DELLE MISURE

### ADVICE FOR THE CORRECT RELEASE OF THE MEASUREMENTS

Prima di iniziare il rilievo è buona regola verificare sempre la linea orizzontale e quella verticale (piombo) del vano.  
Per farlo si consiglia di utilizzare un laser oppure una livella.

Before starting the survey it is a good rule to always check the line horizontal and vertical (plumb) of the compartment. To do this it is recommended to use a laser or a level.

#### A) IN PRESENZA DI LIEVI DIFFERENZE

Le misure vanno sempre prese in 3 punti sia in larghezza che in altezza. La misura da considerare è sempre la minore.

Esempio:  
= 2000 mm  
**= 1998 mm**  
= 1999 mm

Quella da considerare è in questo caso è la .  
Stessa cosa va fatta per la larghezza.

#### A) IN THE PRESENCE OF SLIGHT DIFFERENCES

Measurements must always be taken in 3 points both in width and in height. The measure to be considered is always the smaller.

Example:  
**MIS. H1 = 2000 mm**  
**MIS. H2 = 1998 mm**  
**MIS. H3 = 1999 mm**

The one to consider in this case is **MIS H2** Same thing goes for the width.

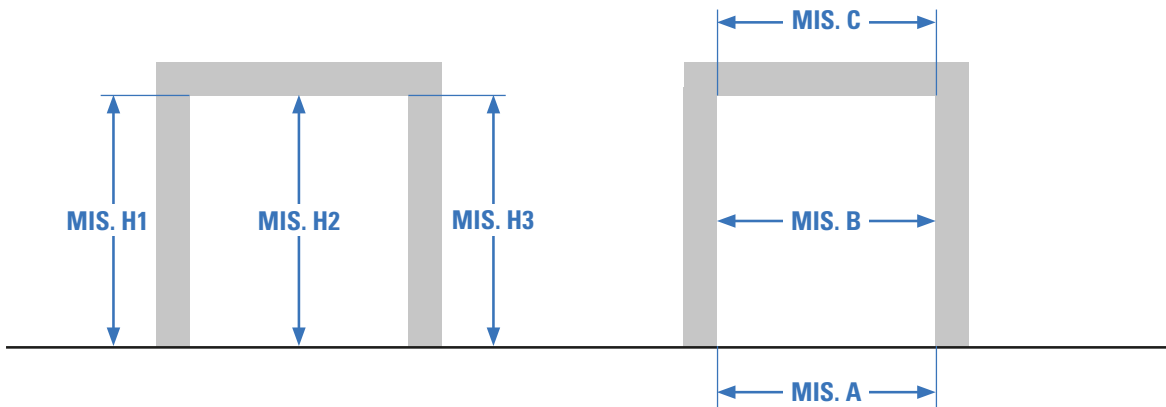

#### B) IN PRESENZA DI GRANDI DIFFERENZE

Qualora il vano presenti disallineamenti importanti il rilievo deve essere eseguito dopo aver tracciato linee verticali ed orizzontali perfettamente in squadra tra loro.  
Eventuali differenze devono essere compensate per permettere un regolare funzionamento dell'infisso.

#### B) IN THE PRESENCE OF GREAT DIFFERENCES

If the compartment presents important misalignments, the survey must be performed after tracing vertical and horizontal lines perfectly squared with each other.  
Any differences must be compensated for to allow regular operation of the system.

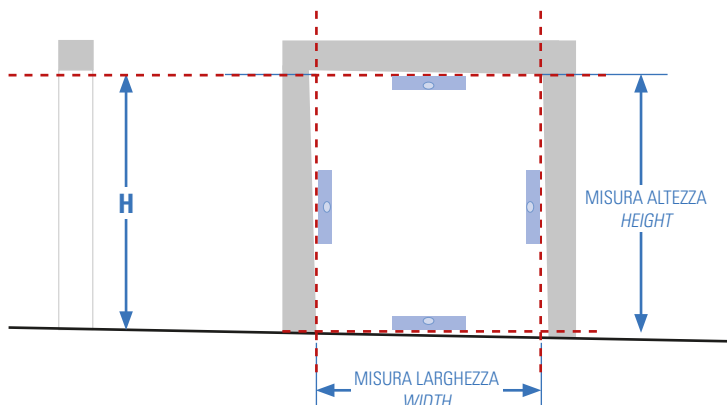

L'infisso verrà prodotto con le dimensioni comunicate senza tener conto di eventuali tolleranze per l'installazione. Si consiglia, allo scopo di agevolare l'installazione, di ridurre le misure vano (misure rilievo) di almeno 5/7 mm in altezza e 5/7 mm in larghezza.

#### THE MEASURES TO BE INDICATED IN THE ORDER FORM MUST BE EXECUTIVE

The frame will be produced with the dimensions communicated without taking account of any tolerances for installation. It is recommended, for this purpose to facilitate installation, to reduce the compartment measures (survey measures) of at least 5/7 mm in height and 5/7 mm in width.

#### THE MEASUREMENTS IN THE FORM MUST BE EXPRESSED IN MILLIMETERS

**GLASS-1000**

Cliente - Customer \_\_\_\_\_

Rif. - Ref. \_\_\_\_\_

**SEZIONE - SECTION**

GLASS-1000

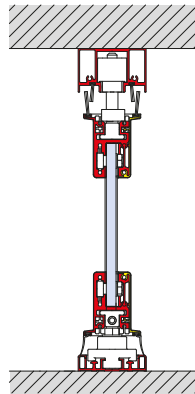

Con guida a pavimento incassata  
With recessed bottom rail

GLASS-1000 + SUP-GRA-110-INC

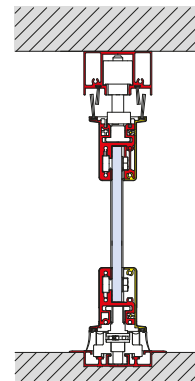

Con guida a pavimento incassata  
With recessed bottom rail

**CARATTERISTICHE GENERALI - GENERAL FEATURES**

Spessore vetro - Glass thickness

10 mm

Misure - Measures



Note particolari - Special notes

Colore struttura - Colour structure

ALLUMINIO ANODIZZATO AN



RAL .....

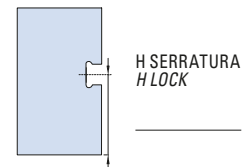

**CONFIGURAZIONE DEI SET E APERTURE - SETS CONFIGURATION AND OPENINGS**

Set 2

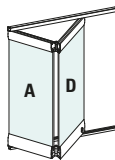

Set 3

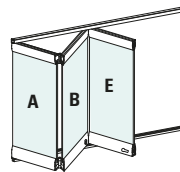

Set 4

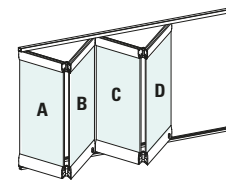

Set 5

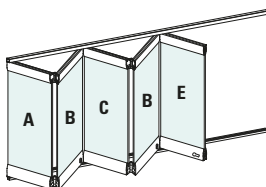



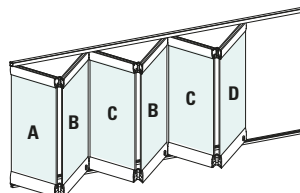

Set 6

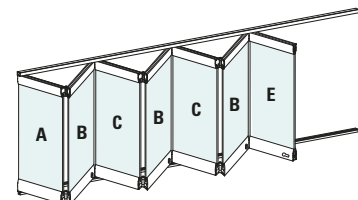

Set 7

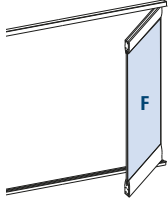
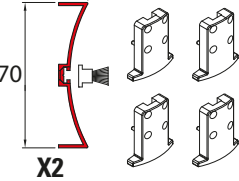
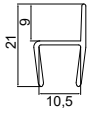
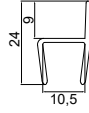

OPTIONALS

<p><b>PRO-V794</b> n° <input type="checkbox"/></p> 	<p><b>PRO-V794-2FLG</b> n° <input type="checkbox"/> Controserratura Strike box</p> 	<p><b>PRO-V794-LG</b> n° <input type="checkbox"/></p> 	
<p><b>GLASS-V900</b> n° <input type="checkbox"/></p>  <p>Kit compreso di maniglia e cilindro chiave/ chiave Kit complete with handle and key/key cylinder</p>	<p><b>GLASS-V900 2FLG</b> n° <input type="checkbox"/></p> 	<p><b>GLASS-1000-ANTA F</b> n° <input type="checkbox"/></p>  <p>Porta laterale fissa Fixed lateral pivoted door</p>	
<p><b>SUP-MONT-GRA-1000</b></p>  <p>Supplemento per 2 montanti laterali, spazzolina e tappi laterali, solo con numero di ante pari. Surcharge for 2 pcs side wall profiles , brush seal and side endcaps, only sets with even number of panels.</p>	<p><b>V-061-E</b> n° <input type="checkbox"/></p> 	<p><b>V-061-T</b> n° <input type="checkbox"/></p> 	<p><input type="checkbox"/> Vetro float extrachiaro Extra clear float glass</p> <p><input type="checkbox"/> Vetro bronzo Bronze glass</p> <p><input type="checkbox"/> Vetro fumè Grey glass</p> <p><input type="checkbox"/> Vetro cool lite riflettente Cool lite glass light reflect</p>
<p><b>WRU-C-BUMP-MT3</b> n° <input type="checkbox"/></p> <p><b>WRU-C-BUMP-MT12</b> n° <input type="checkbox"/></p>	